

# LED Strip Light

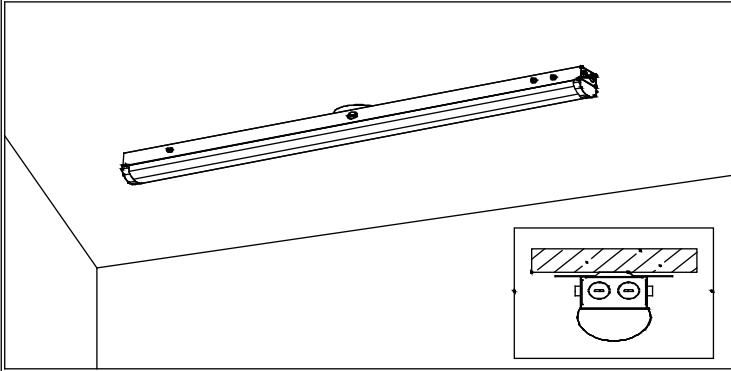

Step1. Punch a hole on the wall and put the expansion tube inside.

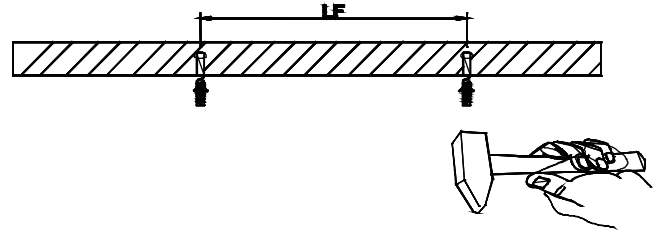

Step2. Press the buckle on both sides and remove

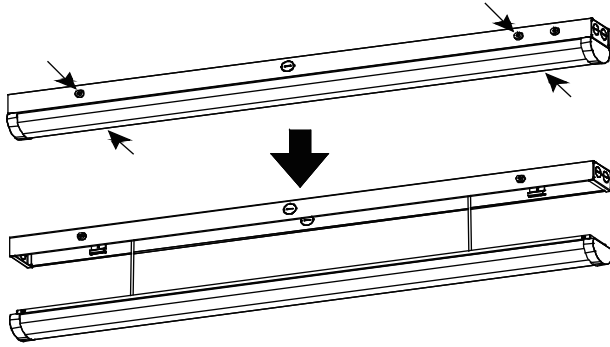

Step3.

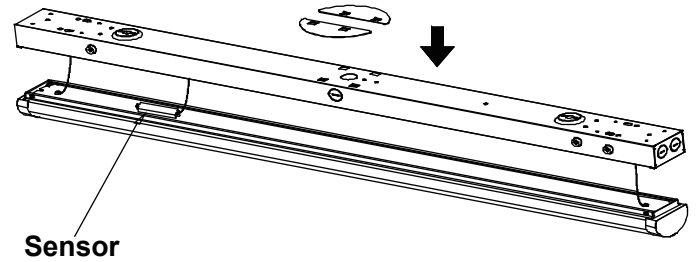

Step4. Secure the fixture on the wall and lock it in tight.

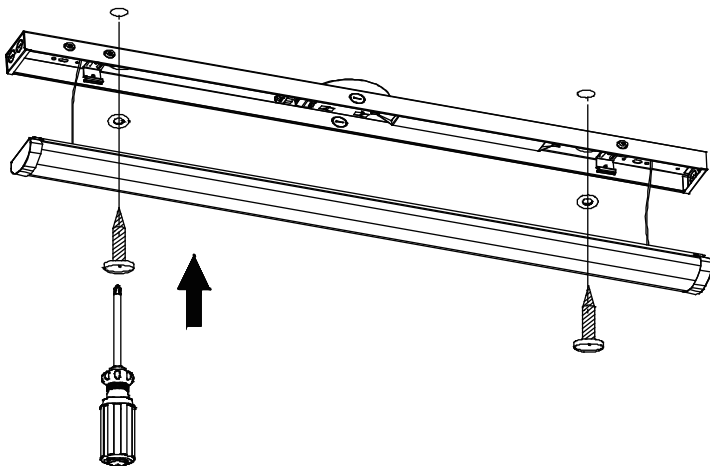

Step5. Turn off the power and wiring by using wire nuts.

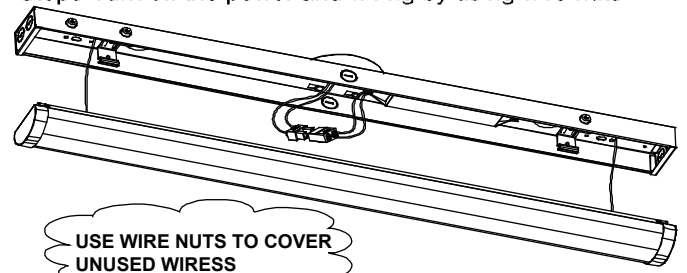

### Wiring Diagram

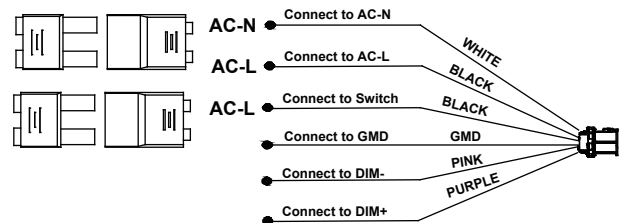

Step6. Press upward the cover and lock it with springs tightly which located into the fixture

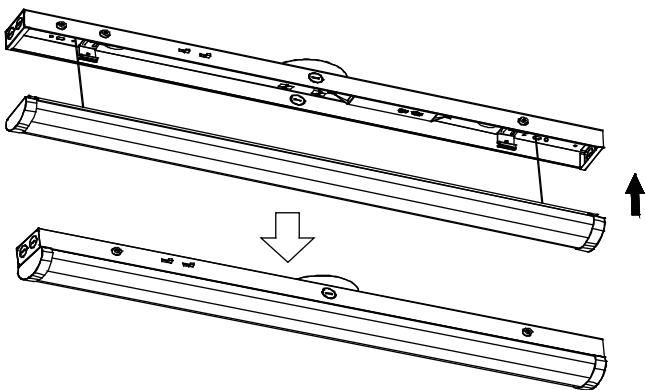

Step7. Installation completed.

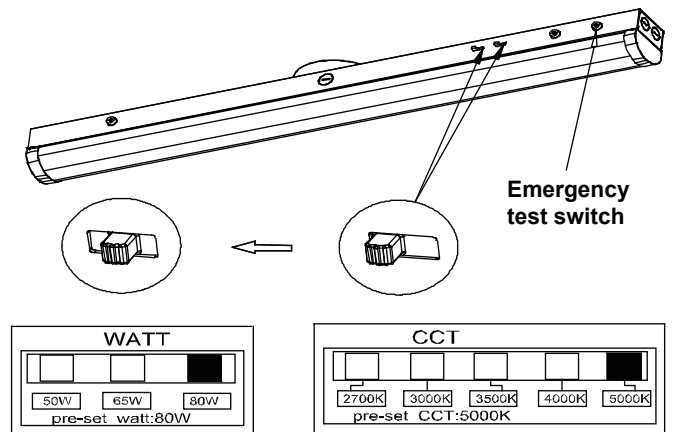

Caution: Please note that DO NOT use this product in the following places/application

1. The place has a large quantity of lampblack and smoke, such as: kitchen and Food processing factory etc.
2. The place has a large quantity of chemical corrosive substance, such as: chemical plant and stockyard etc.
3. The place has poor temperature conditions, large-scale temperature variation, which would easily lead to broken and damage the product, the applicable operating temperature is between -15 and 45 degrees.